

HORSEPOWER RATED

HIGH CURRENT TIMING RELAY

MISSING PULSE DETECTOR LOW COST OPEN BOARD CONSTRUCTION

10 AMPERE RATING 1/3 HP

Series 688B – RETRIGGERABLE ONE SHOT

SOLID STATE

CMOS DIGITAL CIRCUITRY

- Environment Protected
- Tamper Proof Relay
- No False Operate
- Enclosed Relay SPDT OR DPDT
- Small Size – 2.437" x 3.962" x 1.5"
- Lightweight – approximately 2.5 oz.
- Rugged 4 Hole Mounting
- Transient Protected to 6000V

To operate input voltage is applied continuously. A normally open initiate switch closure (either momentary or maintained) causes the load contact to close, energizing the load and start timing. At the end of the preset delay time period the load is turned OFF. Re-closing the initiate switch during timing causes a new timing period to re-start while not affecting the load contact. The load remains energized until there are no timing interrupts and the preset delay has fully elapsed. This timer is often referred to as a "MISSING PULSE DETECTOR".

Control the timing of high power electric heaters, FHP motors, lamps, transformers and other high current loads rated less than 10 amps Resistive. CMOS digital circuitry is combined with high current output relay rated at 10 amps. P/C board and components are covered with a moisture resistant coating. Wiring terminals are ¼ quick connect. Available in all standard voltages and frequencies. Fixed or adjustable timing from .1 seconds to 24 hours.

TIMING DIAGRAM

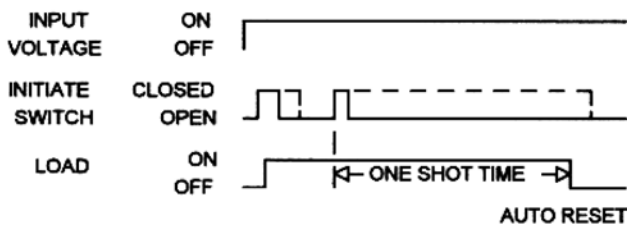

SPECIFICATIONS

1. Repeat Accuracy: $\pm 0.25\%$
2. Combined Effect of Temperature and Voltage upon Repeat Accuracy: $\pm 2\%$ of Setting
3. Reset Time: 150 ms.
4. Operating Voltage Tolerance: $\pm 20\%$
5. Load Current: 10 Amps Resistive at 120/240VAC or 28VDC, 1/3 HP@ 120/240VAC
6. Dielectric Strength: 1500 VRMS
7. Insulation Resistance: 100 Megohms Min.
8. Input Transient Protection: 3000V 120V UNITS, 6000V 240V UNITS
9. Temperature Ambients: Operating -40°C to +70°C Storage -55°C to +85°C
10. Humidity-Operating: 95% Relative
11. Linearity (Option A): $\pm 5\%$ Minimum from 10% to 90% of range
12. Timing Tolerance: $\pm 9\%$ + Tolerance of Rt Std., $\pm 5\%$ Special (Fixed)

HOW TO ORDER 688(N) – (T) (V) (P)

SERIES	(T) = TIME RANGE	(V)=VOLTAGE	(P) = OPTIONS
688B SPDT	P = 0.1 - 5 SEC.	1 = 12VDC	O - CUSTOMER SUPPLIES OWN POTENTIOMETER OR RESISTOR A - POTENTIOMETER SUPPLIED AS LOOSE PART *C - FACTORY FIXED W - POTENTIOMETER WITH WHEEL ON BOARD
	1 = 0.1 - 10 SEC.	2 = 24VDC	
	L = 0.2 - 20 SEC.	3 = 48VDC	
	J = 0.3 - 30 SEC.	4 = 24VAC	
	M = 0.6 - 60 SEC.	5 = 120VAC	
	2 = 1 - 100 SEC.	6 = 240VAC	
	K = 1.2 - 120 SEC.	7 = 110VDC	
	F = 2 - 180 SEC.		
	E = 3 - 300 SEC.		
	3 = 10 - 1000 SEC.		
688BB DPDT	4 = 0.1 - 10 MIN.		<div style="border: 1px solid black; padding: 5px; margin: 10px auto; width: fit-content;"> <i>* For Fixed Time Specify The Value In Seconds, Minutes, Or Hours</i> </div>
	G = 0.3 - 30 MIN.		
	H = 0.6 - 60 MIN.		
	5 = 1 - 100 MIN.		
	V = 3 - 300 MIN.		
	6 = 10 - 1000 MIN.		
	D = 1 - 24 HRS.		

MADE IN USA

EXAMPLE P/N: 688BB-34C/240SEC This is a DPDT, Relay Output RETRIGGERABLE ONE SHOT Solid State 10A Rated Timer with a fixed 240 second delay and an INPUT VOLTAGE of 24 vac. The delay time is factory fixed.

American Control Products / Precision Timer
a division of Prime Technology
344 Twin Lakes Road
North Branford, CT 06471
Telephone: (203) 481-5721
Fax: (203) 481-8937
Email: sales@primetechnology.com
www.primetechnology.com



TECHNICAL BULLETIN

SOLID STATE TIMING MODULE

PAGE 1
OF 2

DATE
11-7-03

688B

REV

TYPICAL CALIBRATION RESISTANCE VS TIME

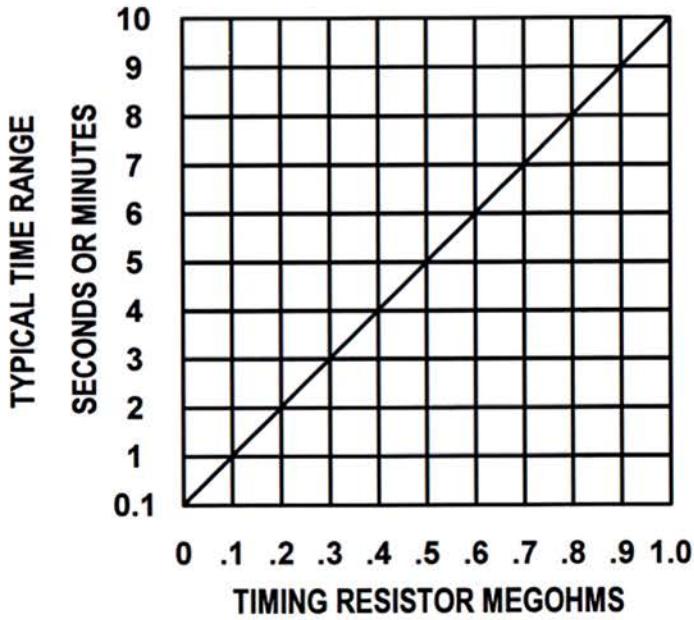

ACCESSORIES AVAILABLE FROM STOCK
CONTROL POTENTIOMETERS (OPTION A)
ORDER P/N PM-1M 1 MEGOHM ± 20%

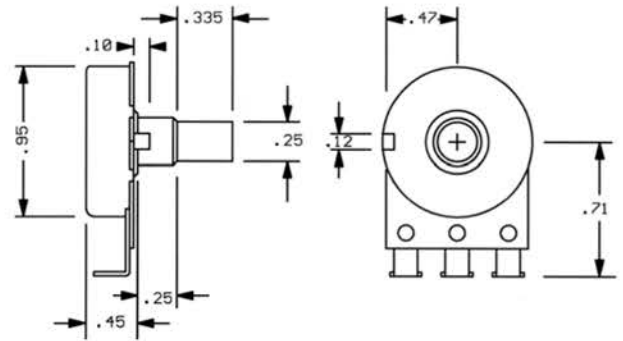

TYPICAL WIRING

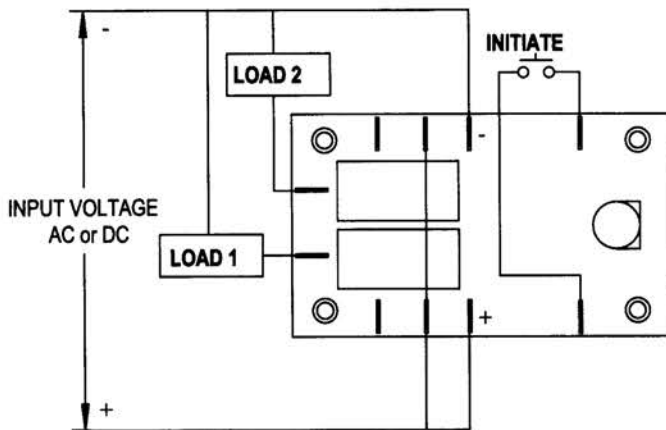

OUTLINE DRAWING

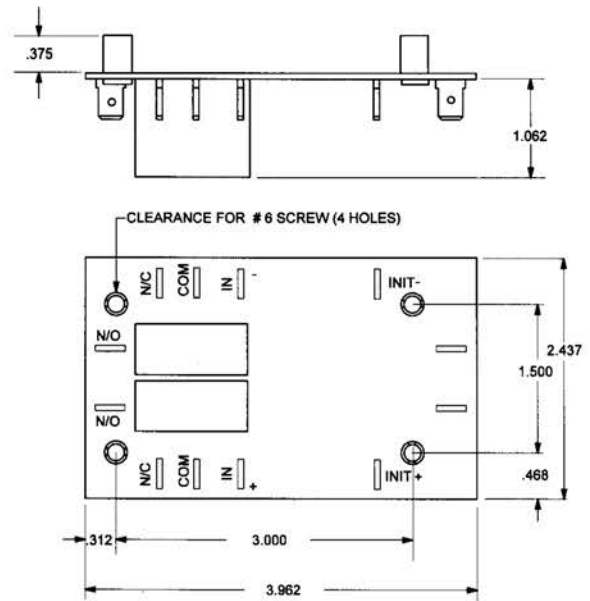

MADE IN USA

American Control Products / Precision Timer
 a division of Prime Technology
 344 Twin Lakes Road
 North Branford, CT 06471
 Telephone: (203) 481-5721
 Fax: (203) 481-8937
 Email: sales@primetechnology.com
 www.primetechnology.com



TECHNICAL BULLETIN

SOLID STATE TIMING MODULE

PAGE 2
OF 2

DATE
11-7-03

688B

REV
B